

TW-HMVI

High Speed Servo Robot Series

Standard Features

Max Load: 11lbs (5kg)
Grease Cover
Mold Close During Ascent
Arm Descent During Mold Open
Central Lubrication with Manifold
Absolute Encoders

Injection Molding
Machine Range

80~350ton

Extract Dry Cycle

0.37sec

Full Dry Cycle

2.53sec

*Dry cycle figures based on standards as evaluated at Star Seiki.
Actual operation values may vary due to environmental factors.



Options

Auto Lubrication
2nd Arm for Stack Mold
Servo Posture Wrist
EOAT Quick Change System

STEC-480

High Performance Pendant with Extensive
Functions & Easy Operability

Easy Operation

- Easy Setting
- Acceleration/Deceleration Setting for Each Point
- Direct Distance Display Function After Pass Operation
- Easy NC Step
- Improved Setup Change Function

Extensive Optional Functions

- Vacuum Pressure Display
- PC Connection
- Web Function
- Multiple Language Capability

Safety

- No Entry Area Setting Function
- One Cycle Check Operation

Energy Saving Function

- Optimized Unloader Cycle (S.I.3)
- Servo Sleep Function (S.I.4)

Eco-Friendliness

- Environmentally Friendly Design



STAR AUTOMATION, INC.

Main Specifications

Power Source	Air Pressure	Drive System	Posture	Posture Torque	Control Box	Air Consumption
AC 200~220 V±10% 50/60Hz	0.49MPa	AC Servo Motor	Air Cylinder 90° Fixed	20.2 N·m (Air Pressure: 0.49MPa)	STEC-480	0.28 ft ³ (8 L/cycle)
Model	Traverse	Crosswise	Vertical	Runner Side Vertical	Injection Press Range (tons)	
TW-800HMVI-480	62.99" / 1600mm	26.77" / 680mm	31.50" / 800mm	33.46" / 850mm	80~250	
TW-1000HMVI-480	70.87" / 1800mm	26.77" / 680mm	39.37" / 1000mm	41.34" / 1050mm	80~350	

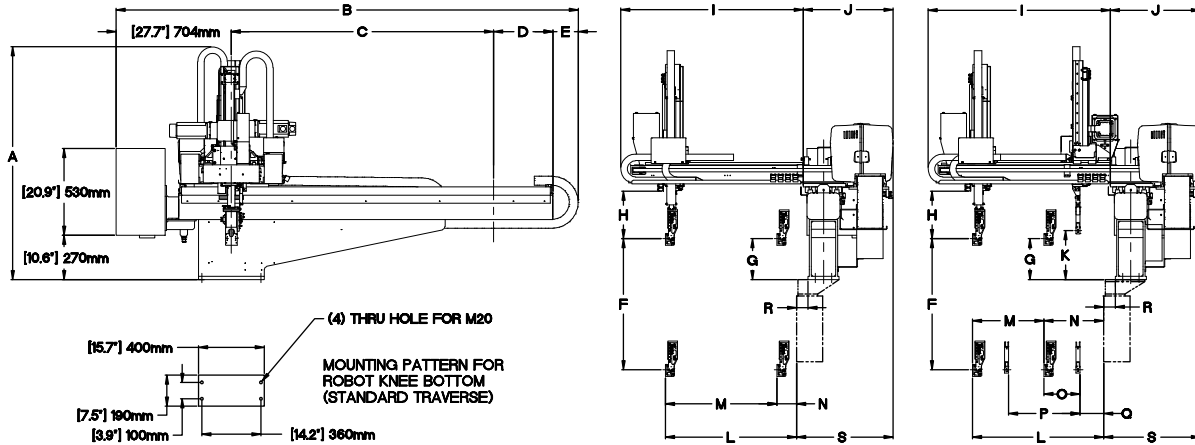

Outer Dimensions		TW-800HMVI	TWS-800HMVI	TW-1000HMVI	TWS-1000HMVI
A	Overall Height	54.96" / 1396mm	55.98" / 1422mm	58.90" / 1496mm	59.92" / 1522mm
B	Overall Width	111.02" / 2820mm		118.90" / 3020mm	
C	Traverse Stroke	62.99" / 1600mm		70.87" / 1800mm	
D	Overhang, Release Side	14.30" / 363mm			
E	Cable Guide Overhang	6.02" / 153mm			
F	(P) Vertical Stroke	31.50" / 800mm		39.37" / 1000mm	
G	(P) Vertical Standby	9.84" / 250mm			
H	Bottom of Crosswise to Chuck Mount Position	11.42" / 290mm			
I	Crosswise Arm	43.82" / 1113mm			
J	Thickness	21.61" / 549mm			
K	(R) Vertical Standby	—	11.81" / 300mm	—	11.81" / 300mm
L	(P) Crosswise Reach	31.50" / 800mm			
M	(P) Crosswise Stroke Max.	26.77" / 680mm	17.13" / 435mm	26.77" / 680mm	17.13" / 435mm
N	(P) Crosswise Standby Min.	4.72" / 120mm	14.37" / 365mm	4.72" / 120mm	14.37" / 365mm
O	(P) (R) Proximity Min.	—	8.66" / 220mm	—	8.66" / 220mm
P	(R) Crosswise Stroke Max.	—	17.13" / 435mm	—	17.13" / 435mm
Q	(R) Crosswise Standby Min.	—	5.71" / 145mm	—	5.71" / 145mm
R	Base Offset	2.76" / 70mm			
S	Mold Mounting Face - Box End	23.23" / 590mm			



Corporate Headquarters

N90 W14401 Commerce Drive
Menomonee Falls, WI 53051
Phone: 262.253.3550
Fax: 262.253.3559

California Office

18141 Beach Boulevard
Unit 195
Huntington Beach, CA 92648
Phone: 714.375.2400
Fax: 714.375.2446

Georgia Office

5555 Oakbrook Parkway
Suite 320
Norcross, GA 30093
Phone: 770.582.9350
Fax: 770.582.9351

Indiana Office

5625 Vogel Road
Unit B
Evansville, IN 47715
Phone: 812.475.9947
Fax: 812.475.9949

Michigan Office

17197 North Laurel Park Dr.
Suite 125
Livonia, MI 48152
Phone: 734.462.9522
Fax: 734.462.9527

Rhode Island Office

860A Waterman Avenue
E Providence, RI 02914
Phone: 401.434.0617
Fax: 401.434.0627

Memphis Tennessee Office

7512 Corporate Centre
Suite 201
Germantown, TN 38138
Phone: 901.737.6407
Fax: 901.737.6408

Nashville Tennessee Office

304 South Lowry Street
Suite D
Smyrna, TN 37167
Phone: 615.223.8666
Fax: 615.223.0640

Texas Office

719 Sawdust Road
Suite 209
Spring, TX 77380
Phone: 281.362.5457
Fax: 281.651.2176