

◎ INJECTION PRESS RANGE: 250-450 TON ◎

Digital AC SERVO Robot Series

TW-1100HMOVII TWS-1100HMOVII



COMMON SPECIFICATIONS

Power Source	Air Pressure	Drive	Posture (air cylinder)	Recommended Max Load	Posture Torque @ 70 PSI	Control Types
200 VAC ± 10% 60 Hz	70 psi (.48 MPa)	AC Servo Motor	90°	22 lbs (10 kg)	40.6 ft-lbs (55.0 N·m)	STEC-520B

GENERAL SPECIFICATIONS

Model	Stroke				Electric Consumption (kVA)	Max Power Consumption (kW)	Main Body Weight (KG)	Air Consumption (ft³)
	(P) Vertical	(R) Vertical	Crosswise	Traverse				
TW-1100HMOVII	47.24" (1200 mm)	N/A	44.49" (1130 mm)	70.87" (1800 mm)	12.0	7.2	978 (2156 lbs)	0.48 (13.5 NI / Cycle)
TWS-1100HMOVII	47.24" (1200 mm)	49.21" (1250 mm)	38.98" (990 mm)	70.87" (1800 mm)	18.0	10.8	1052 (2319 lbs)	0.48 (13.6 NI / Cycle)

STANDARD FEATURE

Vacuum Generator with Part Present Sensor
Part Grip Circuit
Sprue Grip Circuit
USB Port
Ethernet Port
Sample and Chuck Change Positons
Product Packaging (256 each axis)
CNC Step Programming
Micro SD Card
CPC® and AMP® Connections at the Head
Active Vibration Control
IMM Mounting Weldment
Multi- Level Password Protection
Position, Speed and Timer Adjust in Auto
Alarm History
Grease Pocket LM Bearings

OPTION LIST

Additional Vacuum Generator with Part Present Sensor
Additional Part Grip
Nipper on Chuck
Rotation 90°, 180° 2-Position, 180° 3-Position
Shuttle on Tool
Mold Spray
Air Blow
1-3 Color Alarm Light
Special Paint
Free Packaging
Central Lube
Quick Chuck Change
Servo Posture Wrist

OVERALL DIMENSIONS

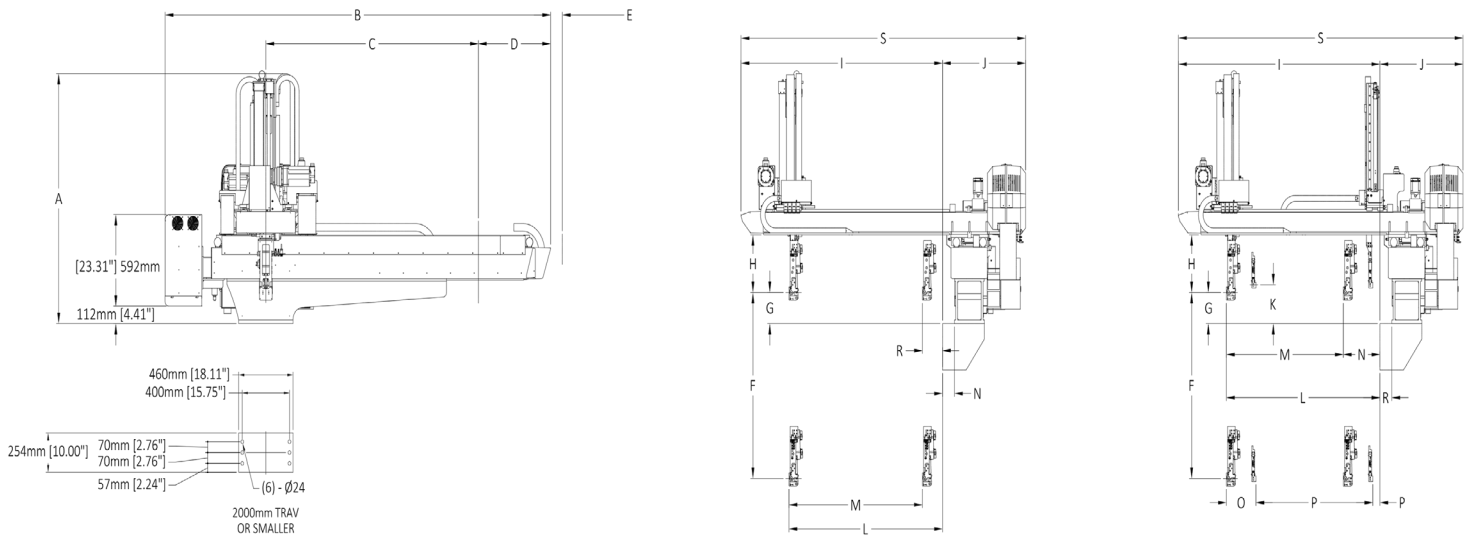

		TW-1100HMVII	TWS-1100HMVII
A	Overall Height	63.54" (1614mm)	63.54" (1614mm)
B	Overall Width	128.50" (3264mm)	128.50" (3264mm)
C	Traverse Stroke	70.87" (1800mm)	70.87" (1800mm)
D	Overhang, Release Side	24.05" (611mm)	24.05" (611mm)
E	Cable Guide Overhang	0	0
F	(P) Vertical Stroke	47.24" (1200mm)	47.24" (1200mm)
G	(P) Vertical Standby	7.87" (200mm)	7.87" (200mm)
H	Bottom of Crosswise to Chuck Mount Postion	14.57" (370mm)	14.57" (370mm)
I	Mold Mounting Face - Crosswise Arm End	67.17" (1706mm)	67.17" (1706mm)
J	Mold Mounting Face - Box End	27.72" (704mm)	27.72" (704mm)
K	(S) Vertical Standby	-	9.84" (250mm)
L	(P) Crosswise Reach Max.	51.18" (1300mm)	51.18" (1300mm)
M	(P) Crosswise Stroke Max.	44.49" (1130mm)	38.98" (990mm)
N	(P) Crosswise Standby Min.	6.69" (170mm)	12.20" (310mm)
O	(P) Proximity Min.	-	9.84" (250mm)
P	(S) Crosswise Stroke Max.	-	38.98" (990mm)
Q	(S) Crosswise Standby Min.	-	2.36" (60mm)
R	Base Offset	3.98" (101mm)	3.98" (101mm)
S	Box End - Crosswise Arm End	94.88" (2410mm)	94.88" (2410mm)

All stated here is subject to change without notice



Wisconsin (HQ)

N90 W14401 Commerce Drive
Menomonee Falls, WI 53051
Phone: 262-253-3550
Fax: 262-253-3559

Email: kscheife@starautomation.com

California

18141 Beach Blvd. Unit 195
Huntington Beach, CA 92648
Phone: 714-375-2400
Fax: 714-375-2446

Email: ryamasaki@starautomation.com

Georgia

5555 Oakbrook Parkway Suite 320
Norcross, GA 30093
Phone: 770-582-9350
Fax: 770-582-9351

Email: chebert@starautomation.com

Indiana

5625 Vogel Road Unit B
Evansville, IN 47715
Phone: 812-475-9947
Fax: 812-475-9949

Email: sberry@starautomation.com

Michigan

17197 North Laurel Park Dr. Suite 125
Livonia, MI 48152
Phone: 734-462-9522
Fax: 734-462-9527

Email: tsukuda@starautomation.com

Rhode Island

860A Waterman Avenue
E Providence, RI 02914
Phone: 401-434-0617
Fax: 401-434-0627

Email: sales@starautomation.com

Tennessee

Sales Phone: 678-428-4202
Service Phone: 615-796-5670
Email: chebert@starautomation.com

Star Seiki Mexico S.A. De C.V.

Bldv Bernardo Quintana #7001
Torre II Oficina 1004 Colonia Centro Sur,
Queretaro, CP. 76090 Mexico
Phone: +52-442-199-5180

Email: knomura@starseikimexico.com